



North America Limited

PRACTICAL USER'S GUIDE FOR THE IN-STUD FIREPLACE

MODEL NUMBER:

V1525BT

V1525RT

Serial Number _____
Model Number _____

Quality checked by: _____

Valued Customer,

We are pleased that you have chosen to purchase an electric fireplace manufactured by Dimplex North America Limited.

Over the years, valuable memories will occur around the warmth and comfort of your hearth. Thank you for allowing our product to be the backdrop for those special moments.

QUICK REFERENCE GUIDE FOR THE IN-STUD FIREPLACE

1. Before using the In-Stud fireplace verify:
 - Are the circuit breakers for the unit on?
 - Are the light bulbs loose? (to check, follow the instructions for replacing the light bulbs under the maintenance section of this manual)
2. The heater may emit a slight, harmless odor when first used. This odor is a normal condition caused by the initial heating of internal heater parts.
3. The information regarding the model of your unit can be found on the rating plate located on the side of the unit. See page 4 for an illustration on how to locate the rating plate.
4. If you have any questions or concerns regarding the operation of your fireplace, contact Dimplex customer service at 1-888-DIMPLEX (1-888-346-7539)

CONTENTS

PAGE 1 – 2	Important Instructions
PAGE 4	Fireplace Installation
PAGE 13	Operation
PAGE 15	Maintenance
PAGE 18	Warranty

IMPORTANT INSTRUCTIONS RETAIN THIS USER'S GUIDE FOR FUTURE REFERENCE

When using electrical appliances, basic precautions should always be followed to reduce the risk of fire, electric shock, and injury to persons.

1. Read all instructions before using the In-Stud fireplace.
2. The heater is hot when in use. To avoid burns, do not let bare skin touch hot surfaces. The trim around the heater outlet becomes hot during heater operation. Keep combustible materials, such as furniture, pillows, bedding, papers, clothes, and curtains at least 3 feet (0.9m) from the front of the unit.
3. Extreme caution is necessary when any heater is used by or near children and whenever the unit is left operating and unattended.
4. Always disconnect power to the fireplace when not in use for extended period of time.
5. Do not operate with a damaged cord or plug (for units supplied with a cord), or if the heater has malfunctioned, or if the fireplace has been dropped or damaged in any manner. Contact Dimplex Customer Services 1-888-346-7539 immediately.
6. Do not use outdoors.
7. Never locate heater where it may fall into a bathtub or other water container.
8. Do not run the cord under carpeting (for units supplied with a cord). Do not cover cord with throw rugs, runners, or the like. Arrange cord away from traffic area and where it will not be tripped over.

9. To disconnect the unit, turn the controls off, and then remove the plug from the outlet or switch off at main power supply panel if the unit is hardwired.
10. Do not insert or allow foreign objects to enter any ventilation or exhaust opening as this may cause an electric shock or fire, or damage to the heater.
11. To prevent a possible fire, do not block air intake or exhaust in any manner.
12. All electrical heaters have hot and arching or sparking parts inside. Do not use in areas where gasoline, paint, or flammable liquids are used or stored or where the unit will be exposed to flammable vapors.
13. Do not modify the fireplace. Use it only as described in this manual. Any other use not recommended by the manufacturer may cause fire, electric shock or injury to persons.
14. This unit may have a polarized plug (one blade is wider than the other). The plug will fit in a polarized outlet only one way. If the plug does not fit fully in the outlet, reverse the plug. If it still does not fit, contact a qualified electrician to install the proper outlet. Do not change the plug in any way. Avoid the use of an extension cord. Extension cords may overheat and cause a risk of fire. If you must use an extension cord, the cord must be No. 16 AWG minimum size and rated no less than 1875 watts.
15. Do not burn wood or other materials in the fireplace.
16. Do not strike the glass front.
17. Always use a certified electrician for build-in hard-wired installation.
18. Always use properly grounded, fused and polarized outlets.

19. Disconnect all main power supply (unplug the unit or switch off at main service panel) before performing any cleaning, maintenance or relocation of the unit.
20. Do not operate the fireplace without the glass assembly and/or frame.
21. When transporting or storing the unit and cord, keep in a dry place, free from excessive vibration and store so as to avoid damage.
22. Do not put combustible material, liquid, small articles such as sand inside glass assembly.

SAVE THESE INSTRUCTIONS

If you have any questions about our products please have the product model and serial numbers available upon calling Dimplex customer service. To locate the model and serial number see below.

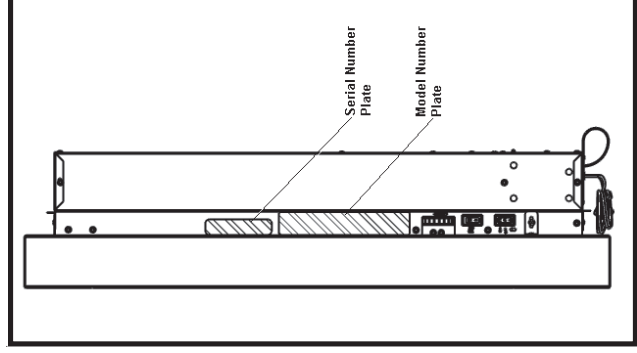

NOTE: Procedures and techniques that are considered important enough to emphasize.

CAUTION: Procedures and techniques, which, if not carefully followed, will result in damage to the equipment.

WARNING: Procedures and techniques, which, if not carefully followed, will expose the user to the risk of fire, serious injury, illness or death.

Step-by-Step Installation

NOTE

A 15amp, 120-volt circuit is required. A dedicated circuit is preferred but not essential in all cases. A dedicated circuit will be required if, after installation, the circuit breaker trips or the fuse blows on a regular basis when the heater is operating. Additional appliances on the same circuit may exceed the current rating of the circuit breaker.

WARNING

Ensure the power cord is not installed so that it is pinched or against a sharp edge and ensure that the power cord is stored or secured to avoid tripping or snagging to reduce the risk of fire, electric shock or injury to persons.

Construction and electrical outlet wiring must comply with local building codes and other applicable regulations to reduce the risk of fire, electric shock and injury to persons.

Do not attempt to wire your own new outlets or circuits. To reduce the risk of fire, electric shock or injury to persons, always use a licensed electrician.

WARNING

The In-Stud fireplace is wall mountable and can be build-in the wall space 16" over-center between 2"x4" wall studs. Follow the installation instructions for either wall mount or built-in mounting; failure to do so may cause damage or injury.

Remove glass assembly before installing fireplace on or into a wall.

- 1. Remove screws securing glass assembly on the mounting tabs. (Figure 1)**
- 2. Use both handles on the sides of the glass assembly, lift and remove the assembly from the fireplace.**
- 3. Please glass assembly with it's back facing down on a flat surface.**

Wall Mounting Instructions:

1. Leave the trim uninstalled until step 9.
2. Select a location for the fireplace, preferably above an electrical outlet and there must be at least one wall stud behind for the fireplace to mount onto. The bottom of the unit must be a minimum of 4" space above the floor (mounting holes 29.5" minimum above the floor). Access to the electrical outlet must be maintained. Ensure the installation meets the national and state/provincial electrical codes.

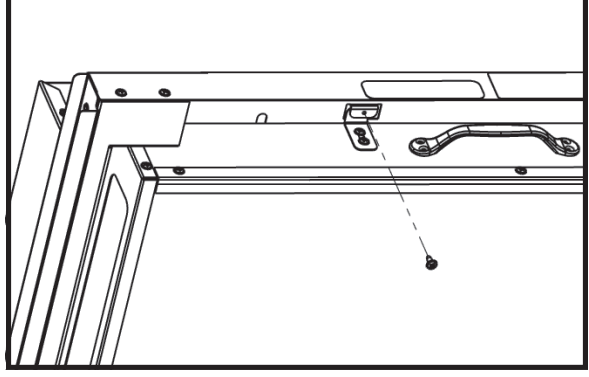

FIGURE 1

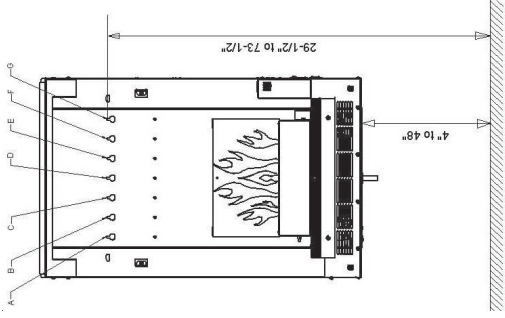

Figure 2

NOTE

It is recommended that the bottom of the unit not be mounted higher than 48" from the ground to maintain an optimized viewing angle of the flame.

CAUTION

The fireplace must be mounted at two points, one of which must be on a wall stud.

WARNING

High temperatures may be generated under certain abnormal conditions. Do not partially or fully cover or obstruct the front of this heater. Bottom of unit must be a minimum of 4" above floor or any surface such as a tabletop to ensure adequate ventilation through air intake located at the bottom of the fireplace. (Figure 3)

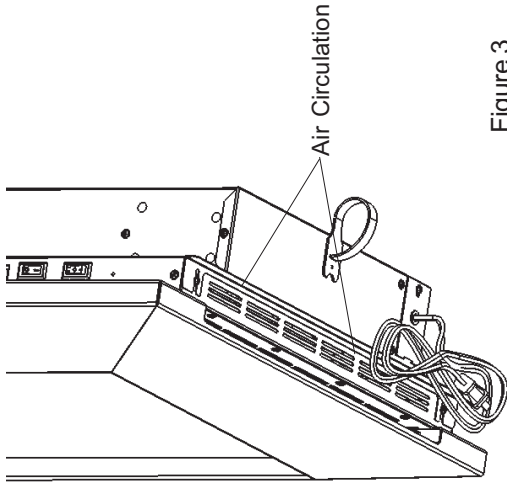

Figure 3

3. With a wall stud finder, locate the center of the wall stud, drive a wood screw into stud and leave approximately 1/8" exposed threads for the fireplace to hang on.
4. The second mounting point should be picked such that it is farthest (to the left or right) relative to the first one among the seven keyholes (A to G shown in figure 2) on the fireplace for wall mounting, these keyholes are 2" apart. For example, if you plan to use hole B as the first mounting hole, the second mounting hole must be G. Other available combinations are A-G, C-G, A-F, A-E, A-D and D-G.
5. Mark the second mounting screw location; ensure that is level with the first with the help of the provided bubble level and the fireplace itself. Screw the threaded drywall anchor in the drywall with a Philip's head screwdriver until the head is flat against the wall surface. Caution should be taken when using a power

tool to install a threaded drywall anchor as the drywall may distort, tear or slightly buckle as a result of over-torque.

6. With a Philip's head screw driver, screw that drywall anchor screw into the drywall anchor already in the wall, leave about 1/8" exposed threads for mounting the fireplace.
7. With the glass assembly taken off, mount the firebox onto the two mounting screws.
8. Tighten both mounting screws with a screwdriver. Be caution not to over tighten the one mated with the drywall anchor.
9. Screw supplied wood screw into corresponding hole that aligns with stud.

(Fig. 2)

10. Re-install glass assembly into fireplace.
11. Install frame onto the firebox as shown in below.

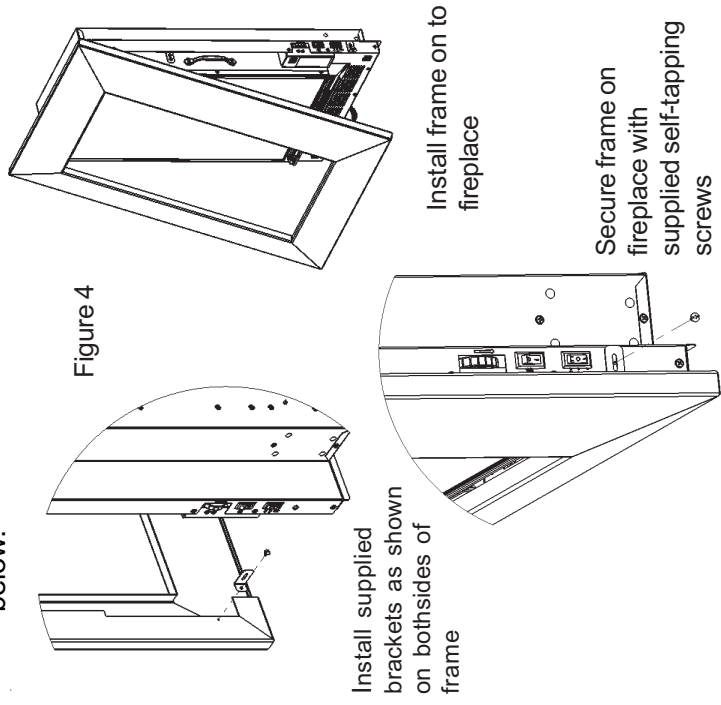

Built-In Instructions:

WARNING

The installation of the fireplace unit must comply with the applicable local and/or national electrical codes and utility requirements. This installation should be entrusted to duly qualified personnel where required by law.

1. Leave the frame uninstalled from the fireplace chassis until step 13.
2. Prepare a wall opening following the dimensions shown in Figure 5. Note that 4" minimum depth including thickness of dry wall is required. Make sure there is enough clearance for the cable coming out from the bottom of the fire place.

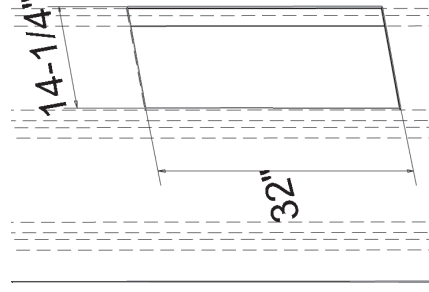

Figure 5

NOTE

Where there are close tolerances involved in wall building or applications which require a great degree of precision, we recommend that the product itself be used to make the actual measurements for the wall opening. Dimplex North America will not be responsible for inaccuracies in the design or manufacture of enclosures.

WARNING

Ensure method of installation does not obscure the air intake slots on bottom of unit in any manner. Keep minimum 4" clearance from bottom of unit to any surface such as the top of a cabinet.

3. Wire a dedicated, properly fused circuit with 120V, 15amp rating. Allow up to 8 feet of service cable for connecting power supply to junction box on fireplace when installing after finishing wall.

CAUTION

Use two conductor, non-metallic sheath cable with ground wire (3 wires total) for the incoming power supply on fireplace inserts. Use appropriate wire to meet local and national electrical codes for rated power consumption.

4. Remove the outer jacket and strip the individual conductor from the end.
5. Loosen the screw securing the junction box cover and remove the cover.
6. Take the cables out from the junction box, loosen the two wire twist nuts and remove the cord set. (FIGURE 6.)

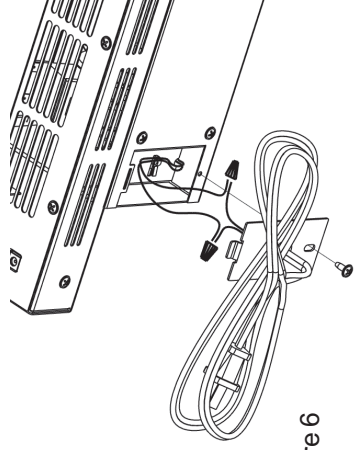

Figure 6

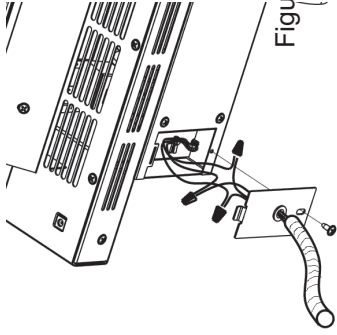
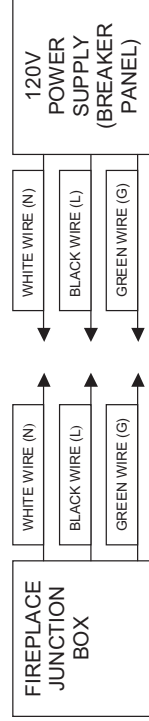

Figure 7

7. Route the power supply wire through the knockout on supplied alternative junction box cover and secure with a wire clamp (not supplied) (FIGURE 7.)
8. Connect the black wire (live) from the unit to the black wire from power supply. (FIGURE 7.)
9. Connect the white wire (neutral) from the unit to the white wire from power supply. (FIGURE 7.)
10. Connect the green wire (ground) from the unit to the green wire from power supply. (FIGURE 7.)

(FIGURE 7.)



11. Place all connectors inside the unit and secure the junction box cover to unit. Ensure that the cable clamp grips only the jacket of service cable.

NOTE

- All wiring must be completed prior to installing the unit into the wall.
12. Place unit in position in the opening, push straight in and attach unit to studs using No. 10 fasteners. Attach supplied wall cover brackets to the top and the bottom of fireplace to cover the gap on the dry wall (Figure 8)

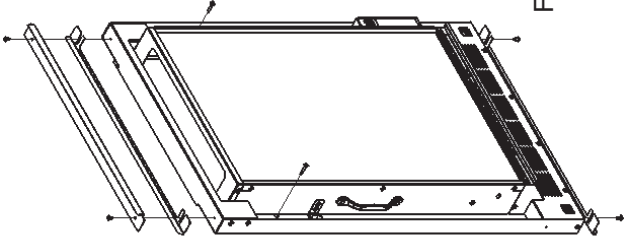

Figure 8

13. Attach fireplace frame as shown in figure 4.

Bathroom Installation

This firebox must be protected by a GFI receptacle or circuit for bathroom use. If receptacle is used it must be readily accessible.

This unit is an electrical appliance that is not watertight and must be installed as to prevent water from entering the unit to prevent electrical shock. This unit must be installed away from showers, tubs, etc.

Never locate fireplace where it may fall into a bathtub or other water containers. Keep towels and other combustible materials 3 feet away from the front of the unit.

Operation

The controls are located on the right hand side of the fireplace. Figure 9.

A. MAIN ON/OFF SWITCH

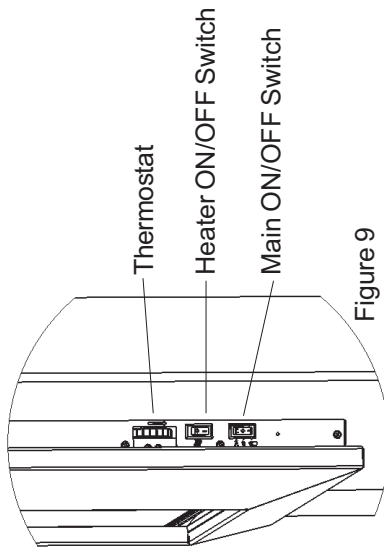



Figure 9

The switch has two ON positions marked  with and "ON".

The "ON" position is for manual operation. In this position the built-in remote control is by-passed.

The  position is for operating the unit with the provided remote control.

When in  position the unit is operated with the ON and OFF buttons of the remote control.

When the switch is in the center position the unit is off.

B. Heater On Switch

The HEAT ON/OFF SWITCH supplies power to the heater fan and the heater element.

When the switch is in the ON position the heater operates if the thermostat calls for heat.

C. Heater Thermostat Control

To adjust the temperature to your individual requirements, turn the thermostat control upward all the way to turn on the heater. When the room reaches the desired temperature, turn the thermostat knob downward until you hear a click. Leave in this position to maintain the room temperature at this setting. For additional heat, turn upward until you hear the click again and the heater will turn on.

Resetting The Temperature Cutoff Switch

Should the heater overheat, an automatic cut out will turn the fireplace off and it will not come back on without being reset. It can be reset by switching the Main ON/OFF switch to OFF and waiting 5 minutes before switching the unit back on.

CAUTION

If you need to continuously reset the heater, disconnect power and call Dimplex customer service at 1-888-DIMPLEX (1-888-346-7539).

Remote Operation

The Fireplace is supplied with an integrated on/off remote control

Note: Ensure that the fireplace Main ON/OFF switch is set to the remote Control setting.

To operate, push the ON button to turn fireplace on, push the OFF button to turn the fireplace off.

Battery Replacement

To replace the battery, slide battery cover open on the hand held transmitter.

Install one 12-volt (A23) battery in the battery holder. Close the battery cover.

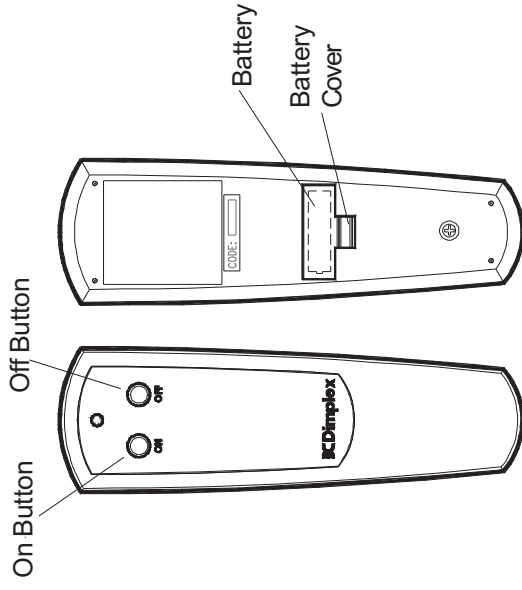

Maintenance

WARNING

Disconnect power before attempting any maintenance or cleaning to reduce the risk of fire, electric shock or damage to persons.

Light Bulb Replacement

Turn unit off, allow at least 5 minutes for light bulbs to cool before touching bulbs to avoid accidental burning of skin.

Light bulbs need to be replaced when you notice a dark section of the flame or when the clarity and detail of the log exterior disappears. There are two bulbs, which generate the flames and embers.

Tool Requirements

Phillips screw driver

Helpful Hints

It is a good idea to replace all light bulbs at one time if they are close to the end of their rated life. Group replacement will reduce the number of times you need to open the unit to replace light bulbs.

Light Bulb Requirements

Quantity of two **40W** Chandelier or candelabra bulbs with E-12 (small) socket base, 120 Volt.

DO NOT EXCEED 40 WATTS PER BULB

Bulb Replacement Instructions:

1. Disconnect power supply to the fireplace either by unplugging the fireplace or switch off at the breaker panel.
2. Remove fireplace front trim.
3. Remove glass assembly. Remove the screws securing the glass assembly on the chassis. Hold on to the handles on the glass assembly with both hands then lift the whole assembly straight up to remove. Figure 10.
4. Remove the two screws securing the light block as shown in Figure 11, then remove the light block.
5. Reach in and turn the burnt-out bulb(s) counterclockwise to remove.
6. Replace with new bulbs.
7. Reassemble light block, glass assembly and fireplace frame in reverse order.

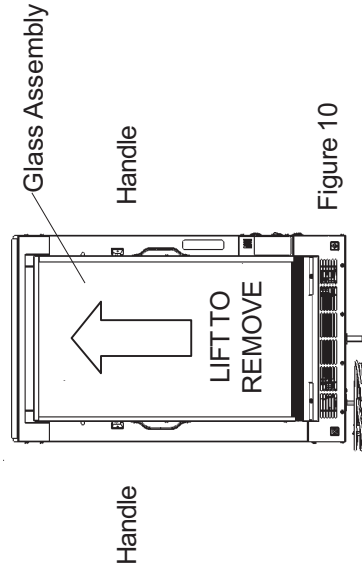

Figure 10

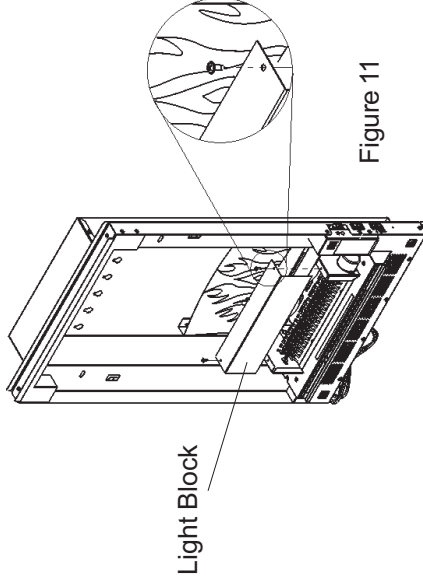

Figure 11

Glass Cleaning

The front glass is cleaned in the factory during the assembly operation. During shipment, installation, handling, etc., the front glass may collect dust particles, these can be removed by dusting lightly with a clean dry cloth.

To remove fingerprints or other marks, the glass can be cleaned with a damp cloth. The glass should be completely dried with a lint free cloth to prevent water spots. To prevent scratching, do not use abrasive cleaners or spray liquids on the glass surface.

Fireplace Surface Cleaning

To remove fingerprints or other marks, the exterior finish can be cleaned with a damp cloth with a mild detergent. The surface should be completely dried with a lint free cloth to prevent water spots.

To prevent scratching, do not use abrasive cleaners or spray liquids on any surface.

One Year Limited Warranty

Products to which this limited warranty applies

This limited warranty applies to newly purchased Dimplex fireplaces and surrounds (mantels) and trims. This limited warranty applies only to purchases made in any province of Canada except for Yukon Territory, Nunavut, or Northwest Territories or in any of the 50 States of the USA (and the District of Columbia) except for Hawaii and Alaska. This limited warranty applies to the original purchaser of the product only and is not transferable.

Products excluded from this limited warranty

Light bulbs are not covered by this limited warranty and are the sole responsibility of the owner/purchaser. Products purchased in Yukon Territory, Nunavut, Northwest Territories, Hawaii, or Alaska are not covered by this limited warranty. Products purchased in these States, provinces, or territories are sold AS IS without warranty or condition of any kind (including, without limitation, any implied warranties or conditions of merchantability or fitness for a particular purpose) and the entire risk of as to the quality and performance of the products is with the purchaser, and in the event of a defect the purchaser assumes the entire cost of all necessary servicing or repair.

What this limited warranty covers and for how long

Products covered by this limited warranty have been tested and inspected prior to shipment and, subject to the provisions of this warranty, Dimplex warrants such products to be free from defects in material and workmanship for a period of 12 months from the date of the first purchase of such product.

The limited 12 month warranty period also applies to any implied warranties that may exist under applicable law. Some jurisdictions do not allow limitations on how long an implied warranty lasts, so the above limitation may not apply to the purchaser.

What this limited warranty does not cover

This limited warranty does not apply to products that have been repaired (except by Dimplex or its authorized service representatives) or otherwise altered. This limited warranty does further not apply to defects resulting from misuse, abuse, accident, neglect, incorrect installation, improper maintenance or handling, or operation with an incorrect power source.

What you must do to get service under this limited warranty

Defects must be brought to the attention of Dimplex Technical Service by contacting Dimplex at 1-888-DIMPLEX (1-888-346-7539), or 1367 Industrial Road, Cambridge Ontario, Canada N1R 7G8. Please have proof of purchase, catalogue/model and serial numbers available when calling. Limited warranty service requires a proof of purchase of the product.

What Dimplex will do in the event of a defect

In the event a product or part covered by this limited warranty is proven to be defective in material or workmanship during the 12 month limited warranty period you have the following rights:

- Dimplex will in its sole discretion either repair or replace such defective product or part without charge. If Dimplex is unable to repair or replace such product or part, or if repair or replacement is not commercially practicable or cannot be timely made, Dimplex may, in lieu of repair or replacement, choose to refund the purchase price for such product or part.
- Limited warranty service will be performed solely by dealers or service agents of Dimplex authorized to provide limited warranty services.
- The purchaser is responsible for removal and transportation of such product or part (and any repaired or replacement product or part) to and from the authorized dealer's or service agent's place of business.

- § This limited warranty does not entitle the purchaser to on-site or in-home services. On-site or in-home services may be performed at the purchaser's specific request and expense at Dimplex's then-current rates for such services.
- § Dimplex will not be responsible for, and the limited warranty services shall not include, any expense incurred for installation or removal of the product or part (or any replacement product or part) or any labour or transportation costs. Such costs shall be the purchaser's responsibility.

What Dimplex and its dealers and service agents are also not responsible for:

IN NO EVENT WILL DIMPLEX, OR ITS DIRECTORS, OFFICERS, OR AGENTS, BE LIABLE TO THE PURCHASER OR ANY THIRD PARTY, WHETHER IN CONTRACT, IN TORT, OR ON ANY OTHER BASIS, FOR ANY INDIRECT, SPECIAL, PUNITIVE, EXEMPLARY, CONSEQUENTIAL, OR INCIDENTAL LOSS, COST, OR DAMAGE ARISING OUT OF OR IN CONNECTION WITH THE SALE, MAINTENANCE, USE, OR INABILITY TO USE THE PRODUCT, EVEN IF DIMPLEX OR ITS DIRECTORS, OFFICERS, OR AGENTS HAVE BEEN ADVISED OF THE POSSIBILITY OF SUCH LOSSES, COSTS OR DAMAGES, OR IF SUCH LOSSES, COSTS, OR DAMAGES ARE FORESEEABLE. IN NO EVENT WILL DIMPLEX, OR ITS OFFICERS, DIRECTORS, OR AGENTS BE LIABLE FOR ANY DIRECT LOSSES, COSTS, OR DAMAGES THAT EXCEED THE PURCHASE PRICE OF THE PRODUCT.

SOME JURISDICTIONS DO NOT ALLOW THE EXCLUSION OR LIMITATION OF INCIDENTAL OR CONSEQUENTIAL DAMAGES, SO THE ABOVE LIMITATION OR EXCLUSION MAY NOT APPLY TO THE PURCHASER.

How State and Provincial law apply

This limited warranty gives you specific legal rights, and you may also have other rights which vary from jurisdiction to jurisdiction. The provisions of the United Nations Convention on Contracts for the Sale of Goods shall not apply to this limited warranty or the sale of products covered by this limited warranty.



1-888-DIMPLEX
1-888-346-7539

DC Dimplex
NORTH AMERICA LIMITED

1367 Industrial Road
Cambridge, Ontario
Canada, N1R 7G8

Approved for use in the United States and Canada