

Owner's Manual

Serial Number:

Model Number:



Power Chef™



Valued Customer,

We appreciate that you have chosen to purchase an electric grill from Dimplex North America Limited. For years to come cherished memories will occur as you gather for good food and fun with family and friends. Thank you for allowing our product to become part of those special memories.

Martyn Champ
President

7208010100REV00

Dimplex®

North America Limited

Dimplex North America Limited
1367 Industrial Road • Cambridge, Ontario • N1R 7G8
800-668-6663 • 800-668-6665 • www.dimplex.com

CONTENTS

Important Instructions	Page 1
Model and Serial Number Information	Page 2
Site Selection and Installation	Page 3
Features	Page 4
Guide to your new Power Chef Electric Grill	Page 6
Control Panel Operating Guide.....	Page 7
Automatic Features.....	Page 8
Operation Manual Mode.....	Page 9
Operation Program Mode	Page 10
Operation F1 Mode.....	Page 12
Care and Cleaning	Page 14
Accessories.....	Page 15
Warranty.....	Page 16

IMPORTANT INSTRUCTIONS

PLEASE SAVE THIS USER'S GUIDE FOR FUTURE REFERENCE

WARNING: Read all instructions and warning labels prior to use. Failure to follow these safeguards may result in serious personal injury or property loss. This appliance is intended for outdoor household, non-commercial use only.

1. Never touch hot surfaces, use handles or knobs. Use cooking tongs, gloves, or cooking mitts at all times since the grill will become very hot. Open hood carefully when cooking to avoid burns from the hot air and steam trapped inside.
2. Wear clothing that does not have hanging shirt tails, frills, or apron strings.
3. Use long-handle barbecue utensils to avoid personal injury caused by burns and splatters.
4. To protect against electric shock, never immerse cord, plugs or electric heating element in water or any other liquid.
5. Never leave the electric grill on when you are not cooking.
6. Unplug the electric grill from outlet when not in use or before cleaning. Allow grill to cool before cleaning or adding or removing parts. Do not clean this product with high pressure hoses.
7. Never operate any appliance with damaged electrical components or after the appliance has malfunctioned. Inspect regularly supply cord and connections. If cord, element or control is damaged or worn, it must be replaced by an authorized service facility as special tools are required. Do not attempt to repair the appliance yourself. Contact your authorized service agent for installation of electrical replacement kit.
8. The use of non Dimplex North America accessory attachments is not recommended and may cause damage to the unit or injury.
9. Never let cord touch hot surfaces.
10. To avoid personal injury, close hood before moving.
11. Never move a hot grill or leave it unattended.
12. Never move an electric grill unless it is unplugged.
13. Never use an electric grill in the rain, sleet or snow.
14. Never use an electric grill near combustible or flammable materials.
15. Turn the power off on the electric grill before unplugging.
16. The use of longer detachable power supply cords or extension cords is not recommended. Extension cords may overheat and cause a risk of fire. If you must use an extension cord, it must be intended for outdoor use have a rating of no less than 1875 watts. Outdoor extension cords are marked with the suffix letters "W-A" and have a tag stating "Suitable for Use with Outdoor Appliances."
17. Store the electric grill out of reach of children.
18. Never allow other persons to be near the electric grill while in use.
19. Warning! Do not use charcoal, or any other combustible material in an electric grill.
20. Do not use this electric grill or it's accessories for anything other than intended use.
21. Always check that food is fully cooked before consumption.
22. Do not attempt to remove the cooking grid from the unit.

POWER CHEF MODEL AND SERIAL NUMBER INFORMATION

If you have any questions regarding our products please have the product model and serial numbers available upon calling Dimplex customer service at 1-888-DIMPLEX (1-888-346-7539). To locate the model and serial number labels see below. Record the model number, serial number, on the front cover of this manual for future reference.

Model Number

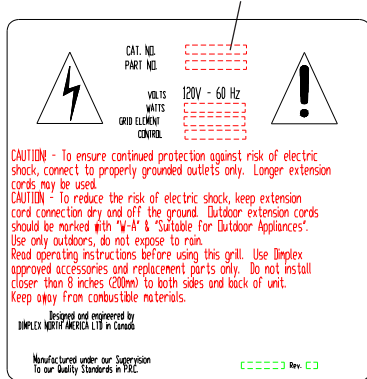

Serial Number

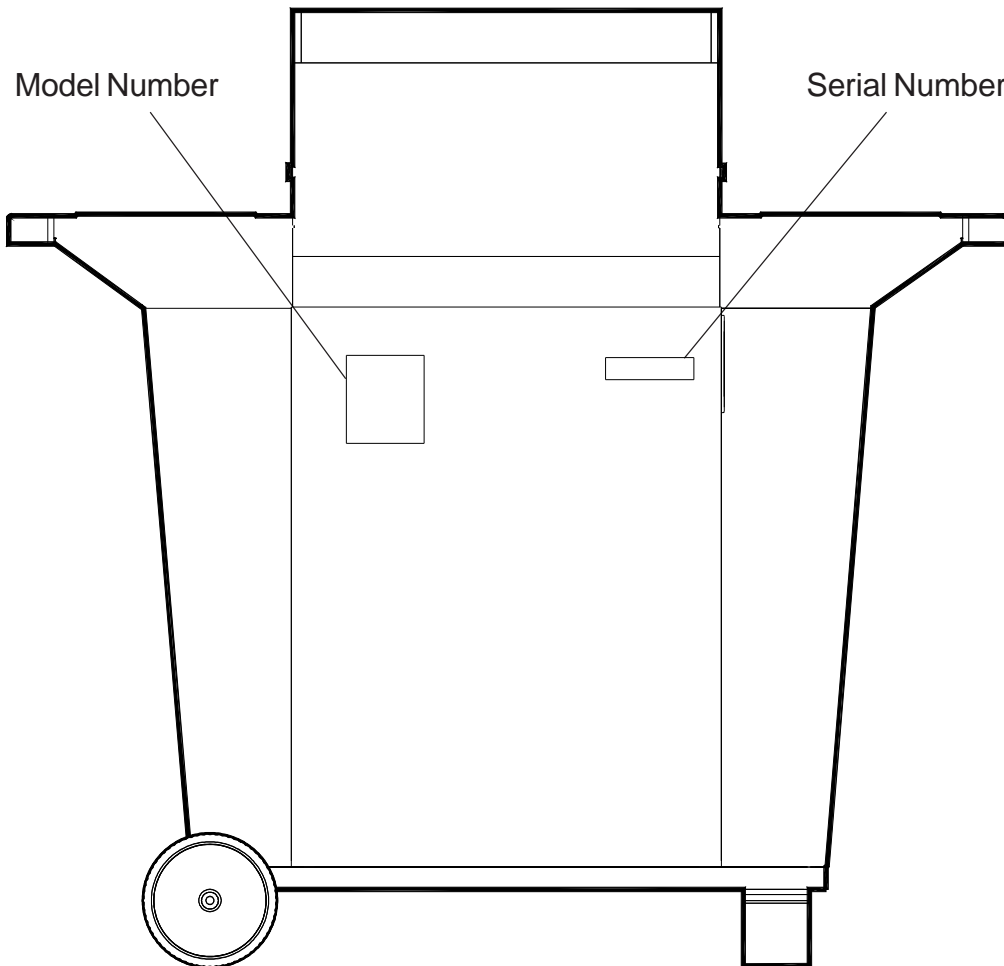
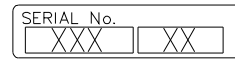

Inside the door on the back panel of the unit

POWER CHEF SITE SELECTION AND INSTALLATION

NOTE

A Ground Fault Interrupt (GFI) outdoor outlet or a circuit protected by a ground fault breaker with a rating of 15 amps, 120 volts is strongly recommended.

A dedicated circuit is preferred but not essential in all cases. A dedicated circuit will be required if, after installation, the circuit breaker trips or the fuse blows on a regular basis when the heater is operating. Additional appliances on the same circuit may exceed the current rating of the circuit breaker.

WARNING

Ensure the power cord is not pinched or against a sharp edge. Ensure that the power cord is stored or secured to avoid tripping or snagging to reduce the risk of fire, electric shock or injury to persons.

Construction and electrical outlet wiring must comply with local building codes and other applicable regulations to reduce the risk of fire, electric shock and injury to persons.

Do not attempt to wire your own new outlets or circuits. To reduce the risk of fire, electric shock or injury to persons, always use a licensed electrician.

INSTALLATION

1. Select a suitable location away from puddles, pools, ponds, and hot tubs.
2. Ensure the electric grill is positioned more than 8" away from any combustible material or surfaces before cooking.
3. Ensure that there are no flammable or other volatile materials in the direct area before grilling.
4. For ease of electrical hook up you may wish to locate the fireplace near an existing outlet. (refer to NOTE).
5. Cover to protect your electric grill after use and for storage. Allow the grill to cool before installing the cover.

The dimensions of the electric grill are 45" wide x 43" high x 20 1/2" deep.

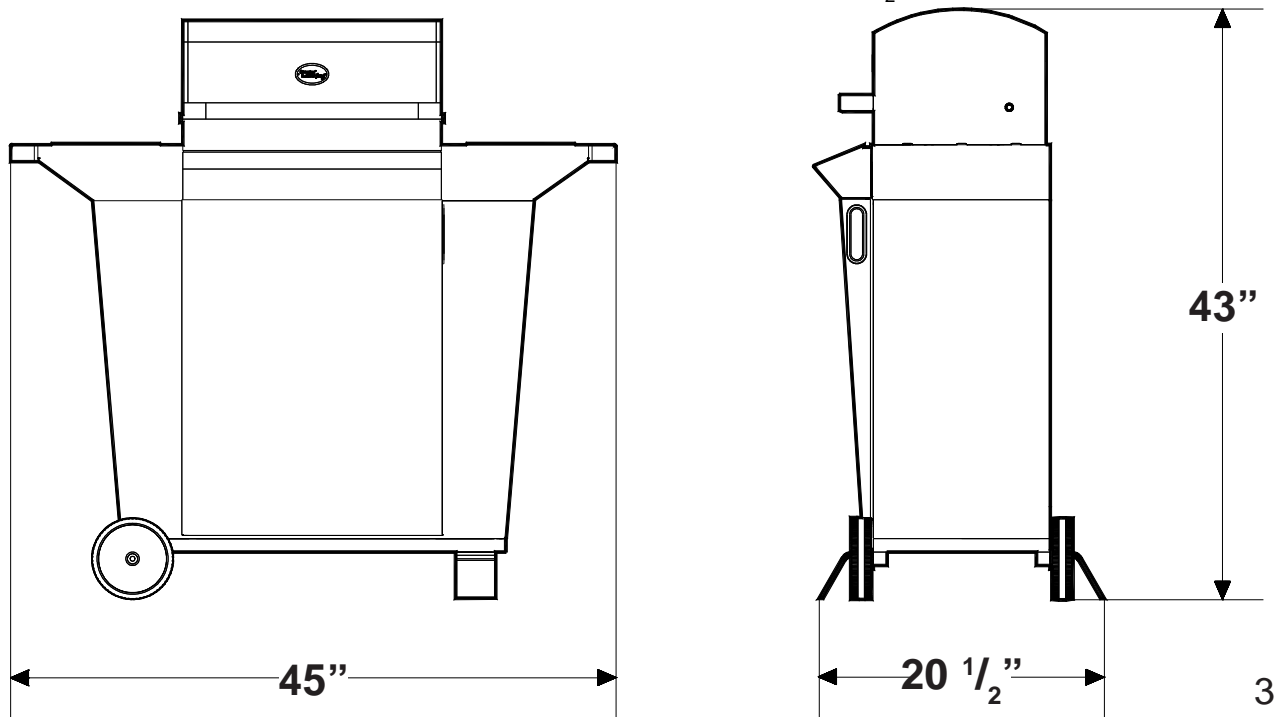

POWER CHEF FEATURES

Welcome and Thank You for purchasing a Dimplex Power Chef™ Electric Grill.

This introduction highlights the many features of the Power Chef™. Detailed operating instructions are contained later on in this brochure.

EvenSear™ Cooking System

At the heart of your Power Chef™ grill is the Even Sear™ Cooking System. The dual layer grill system functions in two ways. The top grill sears your food, with direct contact, and at the same time your food is cooked gently and evenly by additional heat radiating through the lower level element. The Even Sear™ system ensures that all energy supplied to the grill is directly used to cook your food. Energy that would otherwise be wasted heating the cabinetry or air surrounding the food is focused on cooking your food to perfection. The Even Sear™ Cooking System applies energy through both grill layers and flows evenly and consistently throughout the entire grill area, eliminating “hot spots” or “cool spots”.

No unwanted fumes. Safe and Fast.

Power Chef™ utilizes your standard household electric current and provides a closely controlled source of heat to your food. No gas or other fuel fumes will impart unwanted tastes or odor to your food. The Power Chef™ system is safe, with no open flame or combustion, provides fast efficient heat up, and no refueling is ever necessary!

Easy to Clean

With its stainless steel upper grill, the Even Sear™ Cooking System is easy to keep clean. No taste or odor is ever transferred to the food through this high quality grill.

100% Use of Grill

Because there are no variations in temperature or performance, the Even Sear™ Cooking System provides 100% use of its grill area. The full 216 sq. in. grill maintains a consistent even temperature, even in the corners!

Advanced Control System

The Power Chef™ provides precision cooking control in your choice of either MANUAL or PROGRAM modes. To accommodate your specific tastes, audible and visual prompts guide you through your cooking selections and virtually assures food is cooked to perfection.

Program Cooking

The Power Chef's™ advanced cooking control panel provides precision controllability on a wide choice of popular foods, assuring they are cooked to perfection. The control panel prompts you through easy to follow steps in programming multiple food choices, cooking settings and time adjustments. Once programmed, the Power Chef™ prompts you when it is time to start cooking, when it is time to turn your food over and when it is done! Audible signals alert you to each step!

Rotisserie Operation

With a simple repositioning of the Even Sear™ Cooking System into a vertical position your Power Chef™ can function with the optional Rotisserie accessory as a vertical rotisserie bringing the high temperature cooking element into its optimum position for Rotisserie cooking.

POWER CHEF FEATURES

F1 Favourite Cooking

Following the directions in this guide you can program one or more of your favourite cooking times into your Power Chef™. Your favourite food cooked to your own specification, automatically every time!

Manual Cooking

If pre-programmed cooking options don't suit your taste, you can of course prepare your food your way using the Power Chef™ Manual Mode.

Lid Down Cooking

To conserve energy and reduce cooking time, we recommend that the Power Chef™ be used with the lid down during cooking. A typical thermometer featured in many other grills, which reads only the air temperature, inside the cabinetry is unnecessary on the Power Chef™.

Versatile

With no open flame, no combustion and no need to refuel the Power Chef™ can be used safely in many areas that other grills cannot.

GUIDE TO YOUR NEW POWER CHEF ELECTRIC GRILL

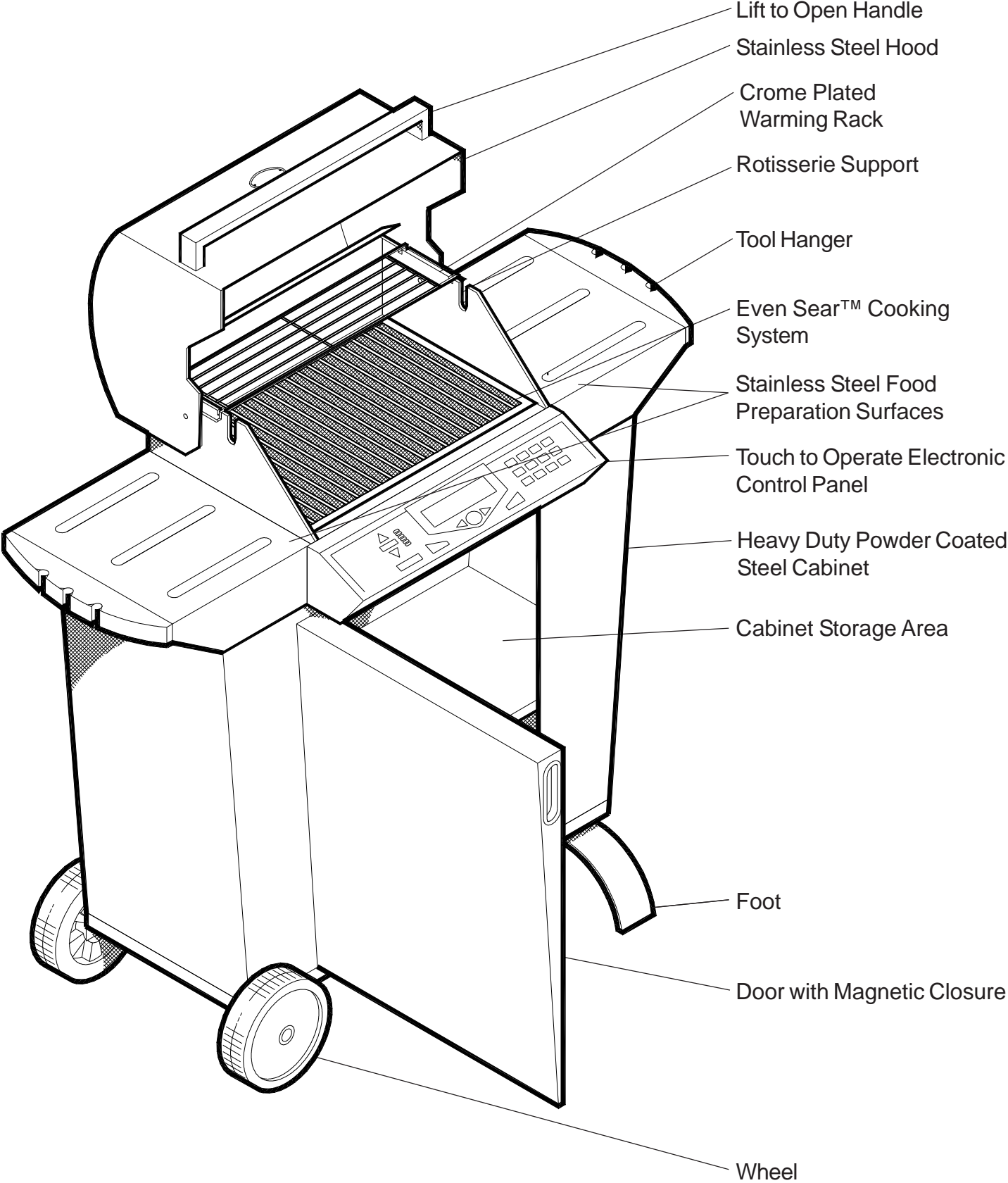

OPERATING GUIDE TO YOUR POWER CHEF CONTROL PANEL

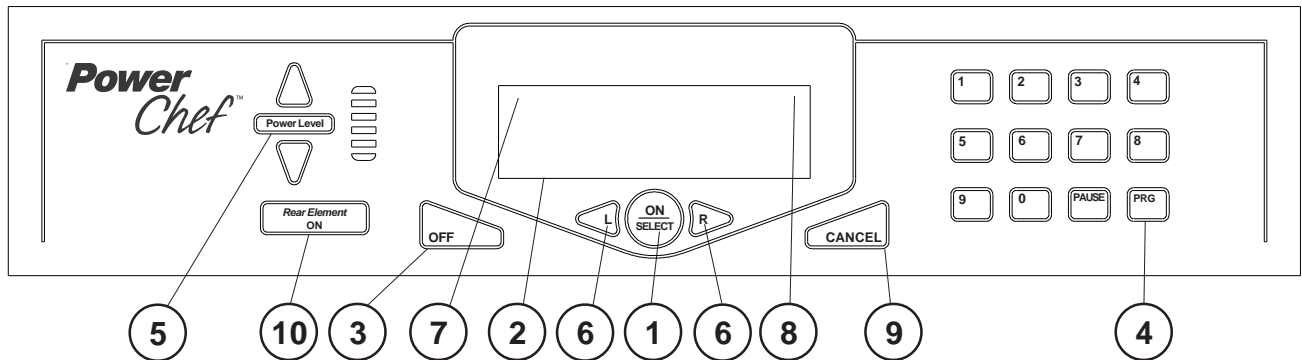

- 1 On/Select**
Use to turn on the unit and to confirm the selections, displayed.
- 2 Display**
Displays selection and status of operation.
- 3 Off**
Push TWICE to shut off entire grill.
- 4 Key Pad**
Use the keypad to set cook timer when in manual operation, F1 or Rotisserie operation.
- 5 Power Level**
Press up/down arrows to select
Use the power level up/down when in manual, rotisserie or F1 modes only.
- 6 Right/Left Arrows**
Use to navigate display selections.
- 7 Total Timer**
Shows the remaining cooking time when in program mode. The timer can also be used when in manual and rotisserie operation as a time counter.
- 8 Stage Timer**
Counts down remaining cooking time for each stage when in program mode.
- 9 Cancel**
Cancels the last selection from the display.
- 10 Rear Element On**
Turns rear element on for rotisserie operation.

AUTOMATIC FEATURES OF THE POWER CHEF CONTROL PANEL

Automatic Power Saver

This feature activates immediately after a pre-programmed selection is finished cooking and "DONE" is shown on the display. The cooking system power will shut off but the display will remain ON.

Safety Power-off

This feature activates if the unit has been accidentally left on after cooking. Four hours after the last button has been touched on the control panel the power automatically shuts off to the entire unit.

Sleep Mode

When using the program mode and the On/Select button is not pressed after a stage of cooking the power will automatically reduce to the minimum one bar level after a short period of time to prevent the food from burning.

Voltage Compensation

The electric grill automatically adjusts the cook times based on any variance to input voltage. This insures food is grilled to the desired state.

Key Lock

This feature is useful in that it prevents accidental changes to your cooking program by locking the control panel when in use. When this feature is used all control panel functions are disabled. To activate the key lock press the numbers in sequence 1,2,3 LOC will appear on the display screen. To deactivate the key lock press the numbers in sequence 1,2,3 and ULOC will appear on the display screen.

POWER CHEF OPERATION - MANUAL MODE

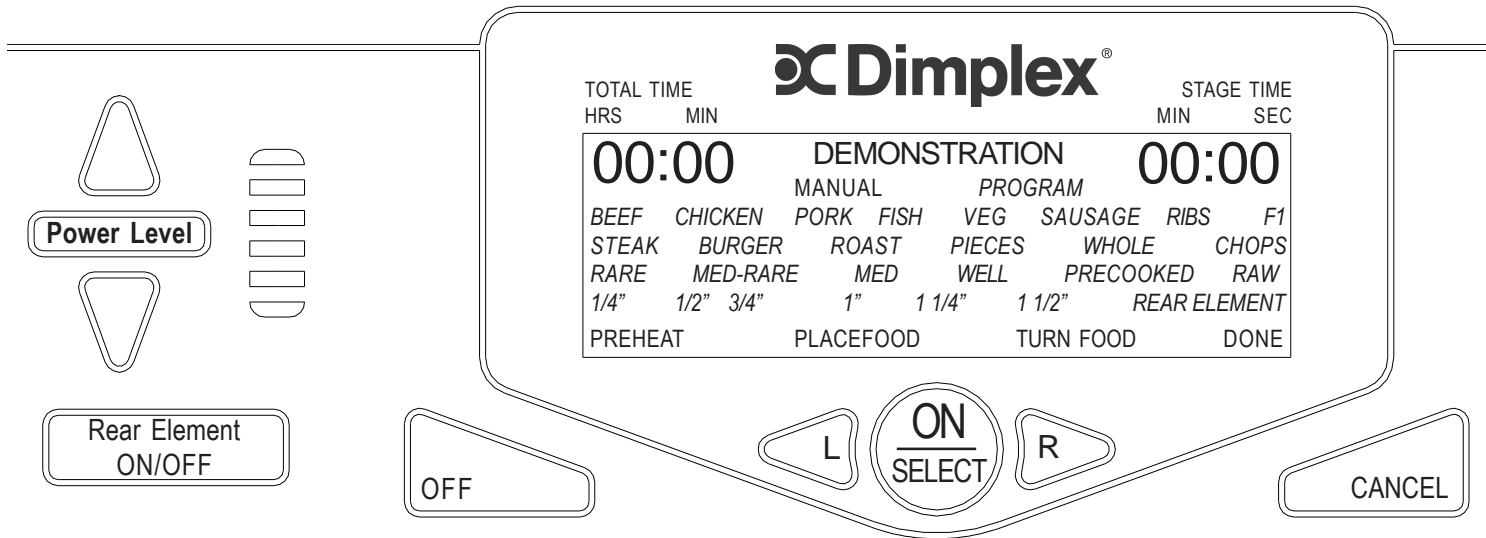

Operation	Display Reads	Activity
To Use the Manual Feature		
Touch On/Select button	<i>MANUAL</i> (Flashing)	Initial Start-Up
Touch On/Select button & manual	<i>PREHEAT</i>	Preheat for 8 minutes
Alarm Sounds	<i>PLACE FOOD</i>	Grill Ready - Place Food
Close Hood		Cooking is underway
Touch Up/Down Power Keys	Power Level	Increases/Decreases Power Setting
Touch Off Twice	Blank	Turn off when finished

Note: The timer can be used as a reference when in manual mode.

Operation	Display Reads	Activity
To Use the Timer with the Manual Feature		
Touch On/Select button	<i>MANUAL</i> (Flashing)	Initial Start-Up
Touch On/Select button & manual	<i>PREHEAT</i>	Preheat for 8 minutes
Alarm Sounds	<i>PLACE FOOD</i>	Grill Ready - Place Food
Close Hood		Cooking is underway
Touch Up/Down Power Keys	Power Level	Increases/Decreases Power Setting
Touch Key Pad Keys	Total time displays minutes entered from key pad	Count down timer is now entered
Touch On/Select button	Total time begins to count down from time entered on key pad	Timer is now activated

***Note: When the timer reaches 0 the power to the cooking frid shuts off. Touch the On/Select button to shut the display off.

POWER CHEF OPERATION - PROGRAM MODE

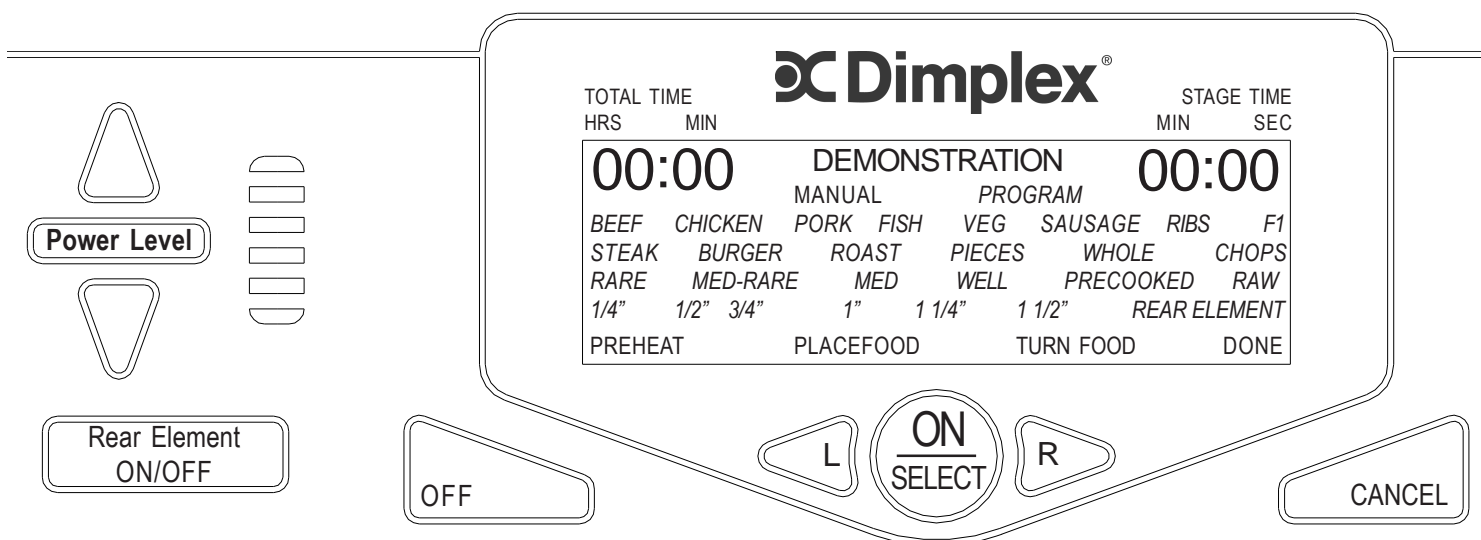

Operation	Display Reads	Activity
To Set Program Mode		
Touch On/Select button	<i>MANUAL</i> (Flashing)	Initial Start-Up
Touch Right Arrow	<i>PROGRAM</i>	Shifts operation from Manual to Program Mode
Touch On/Select	<i>PROGRAM</i>	Completes Program Mode Set Up
To Cook your Selected Food		
Touch Right/Left Arrows until choice is illuminated	<i>BEEF</i>	Visual display highlights primary food selection
	<i>CHICKEN</i>	
	<i>PORK</i>	
	<i>FISH</i>	
	<i>VEGETABLES</i>	
	<i>SAUSAGE</i>	
Touch On/Select button	Your choice remains illuminated	Selects primary food choice

Depending on your food choice, you will be prompted to highlight and select secondary food choice description. (e.g. Beef Steak or Beef Burgers). Use the Right/Left Arrow and the On/Select button to highlight and select your choice.

Depending on your food choice, you may be prompted to select how you want your food prepared. (e.g. Rare, Medium Rare, Medium or Well Done). Use the Right/Left Arrow button and the On/Select button to highlight and select your choice.

Depending on your food choice, you may be prompted to select the thickness of the food to be cooked. (e.g. 1/4", 1/2", 3/4", 1", 1 1/4", 1 1/2"). Use the Right/Left Arrow button and the On/Select button to highlight and select your choice.

Once your food and cooking choices have been selected:

POWER CHEF OPERATION - PROGRAM MODE

Once your food and cooking choices have been selected:

Operation	Display Reads	Activity
Food Choice Selections (as above)	<i>PREHEAT</i> Stage Timer begins to count down from 8 minutes. Total Timer displays total cooking time.	Grill is fully powered and is preheating.
Alarm Sounds	<i>PREHEAT</i> changes to <i>PLACE FOOD</i> Total Time pauses.	Grill is fully preheated and ready to cook.
Place foods on grill and close hood. Touch On/Select button.	<i>PLACE FOOD</i> indicator goes off. Total Timer re-commences to countdown. Stage Timer counts down to next stage.	Cooking is underway.
Alarm sounds to turn food over.	<i>TURN FOOD</i> appears Total Timer pauses. Stage Time is completed.	Grill is indicating it is time to turn food over.
Turn food over and close the hood. Touch On/Select button	<i>TURN FOOD</i> goes off. Total Timer resumes. Stage Timer counts down to next stage.	Cooking of reverse side of food commences.

Depending on your food choice and cooking choice, you may be prompted to repeat the last two steps.

Note:

All program cooking times assume food is thawed before cooking (except hamburger patties).

Operation	Display Reads	Activity
Alarm Sounds	<i>DONE</i> highlighted Total and Stage Timers go off.	Food cooking program is completed.
Touch On/Select or Cancel button to finish the program.	All indicators are off.	Food cooking program is completed.
Touch Off button	All indicators are off.	Shutdown grill.

POWER CHEF OPERATION - F1 MODE

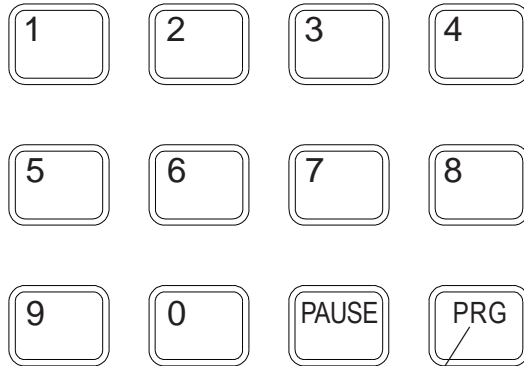
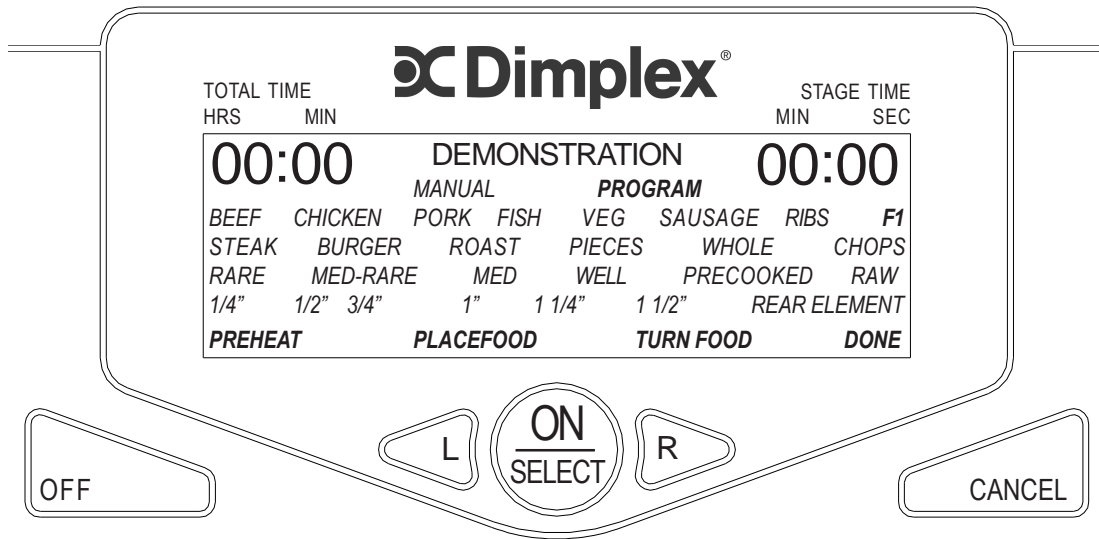

Key Pad Program Button

POWER CHEF OPERATION - F1 MODE

Operation	Display Reads	Activity
To Use F1 Manual Feature		
Touch On/Select button	<i>MANUAL</i> (Flashing)	Initial Start-Up
Touch Right Arrow	<i>PROGRAM</i>	Shifts operation from Manual to Program Mode
Touch On/Select button	<i>BEEF</i> (Flashing)	Allows you to select desired programmed setting
Touch Right/Left Arrows until choice is F1 flashing	<i>BEEF</i>	
	<i>CHICKEN</i>	
	<i>PORK</i>	
	<i>FISH</i>	
	<i>VEGETABLES</i>	
	<i>SAUSAGE</i>	
	<i>RIBS</i>	
Touch PRG button on Key Pad	t1 Stage Time displays preset time (will display default of 0:00 for first time use)	Allows you to set cook time for first programmed favorite
Touch number 1 - 0 on keypad to set cook time ** stage times can be cleared by pressing cancel	t1 Stage Time displays preset time	Cook time is now set for first programmed favorite
Touch Right/Left Arrows	P1 L1	Allows you to set power level for first programmed favorite
Touch 1 - 6 on keypad or up/down arrows on Power Level selection	P1 L(number selected for power level)	Power level is now set for first programmed favorite
Touch PRG button on Key Pad	F1 (flashing)	Favorite is set and ready to use for cooking
Touch On/Select button	Stage Timer begins to count down from 8 minutes. Total Timer displays total cooking time.	Grill is fully powered and is preheating
Alarm Sounds	<i>PREHEAT</i> changes to <i>PLACE FOOD</i> Total Time pauses.	Grill is fully preheated and ready to cook.
Place foods on grill and close hood. Touch On/Select button.	<i>PLACE FOOD</i> indicator goes off. Total Timer re-commences to countdown. Stage Timer counts down to next stage.	Cooking is underway.
** Note: Up to 8 Favorites can be programmed each with it's own time and power level. To program additional Favorites or to modify any previously programmed Favorites repeat steps listed above.		

POWER CHEF CARE AND CLEANING

To keep your electric grill operating at its best possible performance Dimplex recommends that you clean the cooking grid and rotisserie after each use.

Unplug the electric grill from outlet when not in use or before cleaning.

Allow the grill to cool before cleaning. Do not clean this product with high pressure water spray.

Do not use abrasive powders or cleaning pads on any surface of the electric grill.

Allow electric grill to cool before covering.

Cover the electric grill when not in use.

Storage

For seasonal storage, cover and store in a dry location away from the elements.

Control Panel Glass

To clean the control panel glass use a non abrasive glass cleaner or damp, soft cloth or sponge with a mild detergent. Follow with a clean damp cloth to remove any remaining detergent residue. Buff dry.

Drip Tray

The drip tray is located under the cooking grid and is permanently mounted.

The drip tray can be lined with aluminum foil and/or we recommend the use of a non-stick cooking spray to make clean-up easier.

To clean;

Open the hood and locate the cooking grid.

The cooking grid may be lifted from the front into the vertical rotisserie cooking position to gain access to the drip tray.

Use a damp, soft cloth or sponge with a mild detergent. Follow with a clean damp cloth or paper towel to remove any remaining detergent residue.

Relocate the cooking grid into position in the body of the electric grill before use.

Grease Cup

The grease cup is secured to the bottom of the electric grill.

To clean;

Open the cabinet door and locate the grease cup, turn to release.

Drain the grease cup and wipe any residue with a cloth or paper towel.

Re-install the grease cup before use.

Cooking Grid

The cooking grid is permanently mounted into the body of the electric grill,

DO NOT ATTEMPT TO REMOVE.

To clean;

Clean cooking surface with a damp, soft cloth or sponge with a mild detergent. Follow with a clean damp cloth to remove any remaining detergent residue. A soft wire brush or plastic scraper may be used to remove excess deposits.

To clean under the cooking grid, tilt by lifting from the front.

Relocate the cooking grid into position in the body of the electric grill before use.

Warning: Never strike cooking grid to remove residue

Stainless Steel Surfaces

Clean all stainless steel panels with a damp, soft cloth or sponge with a mild detergent.

Follow with a clean damp cloth to remove any remaining detergent residue. Buff dry. **DO NOT USE OVEN CLEANER, ABRASIVE SCOURING POWDERS OR ABRASIVE CLEANING PADS AS THEY MAY SCRATCH.**

Painted Panels

Clean all painted panels with a damp, soft cloth or sponge with a mild detergent. Follow with a clean damp cloth to any remaining detergent residue. Buff dry.

POWER CHEF ACCESSORIES

Contact your Dimplex Electric Grill dealer for optional accessories.

Rotisserie

Plug in rotating spit for cooking meat or vegetables. Installs in front of the cooking grid and requires a separate outlet to power the rotating rotisserie motor.

Grill Cover

A durable cover to protect your electric grill after use and for storage. Allow the grill to cool before installing the cover.

ONE YEAR LIMITED WARRANTY

Products to which this limited warranty applies

This limited warranty applies to newly purchased Dimplex electric grill. This limited warranty applies only to purchases made in any province of Canada *except* for Yukon Territory, Nunavut, or Northwest Territories or in any of the 50 States of the USA (and the District of Columbia) *except* for Hawaii and Alaska. This limited warranty applies to the original purchaser of the product only and is not transferable.

Products excluded from this limited warranty

Products purchased in Yukon Territory, Nunavut, Northwest Territories, Hawaii, or Alaska are not covered by this limited warranty. Products purchased in these States, provinces, or territories are sold AS IS without warranty or condition of any kind (including, without limitation, any implied warranties or conditions of merchantability or fitness for a particular purpose) and the entire risk of as to the quality and performance of the products is with the purchaser, and in the event of a defect the purchaser assumes the entire cost of all necessary servicing or repair.

What this limited warranty covers and for how long

Products covered by this limited warranty have been tested and inspected prior to shipment and, subject to the provisions of this warranty, Dimplex warrants such products to be free from defects in material and workmanship for a period of 12 months from the date of the first purchase of such product.

The limited 12 month warranty period also applies to any implied warranties that may exist under applicable law. Some jurisdictions do not allow limitations on how long an implied warranty lasts, so the above limitation may not apply to the purchaser.

What this limited warranty does not cover

This limited warranty does not apply to products that have been repaired (except by Dimplex or its authorized service representatives) or otherwise altered. This limited warranty does further not apply to defects resulting from misuse, abuse, accident, neglect, incorrect installation, improper maintenance or handling, or operation with an incorrect power source.

What you must do to get service under this limited warranty

Defects must be brought to the attention of Dimplex Technical Service by contacting Dimplex at 1-888-DIMPLEX (1-888-346-7539), or 1367 Industrial Road, Cambridge Ontario, Canada N1R 7G8. Please have proof of purchase, catalogue/model and serial numbers available when calling. Limited warranty service requires a proof of purchase of the product.

What Dimplex will do in the event of a defect

In the event a product or part covered by this limited warranty is proven to be defective in material or workmanship during the 12 month limited warranty period you have the following rights:

- Dimplex will in its sole discretion either repair or replace such defective product or part without charge. If Dimplex is unable to repair or replace such product or part, or if repair or replacement is not commercially practicable or cannot be timely made, Dimplex may, in lieu of repair or replacement, choose to refund the purchase price for such product or part.
- Limited warranty service will be performed solely by dealers or service agents of Dimplex authorized to provide limited warranty services.
- The purchaser is responsible for removal and transportation of such product or part (and any repaired or replacement product or part) to and from the authorized dealer's or service agent's place of business.

ONE YEAR LIMITED WARRANTY

- Dimplex will not be responsible for, and the limited warranty services shall not include, any expense incurred for installation or removal of the product or part (or any replacement product or part) or any labour or transportation costs. Such costs shall be the purchaser's responsibility.

What Dimplex and its dealers and service agents are also not responsible for:

IN NO EVENT WILL DIMPLEX, OR ITS DIRECTORS, OFFICERS, OR AGENTS, BE LIABLE TO THE PURCHASER OR ANY THIRD PARTY, WHETHER IN CONTRACT, IN TORT, OR ON ANY OTHER BASIS, FOR ANY INDIRECT, SPECIAL, PUNITIVE, EXEMPLARY, CONSEQUENTIAL, OR INCIDENTAL LOSS, COST, OR DAMAGE ARISING OUT OF OR IN CONNECTION WITH THE SALE, MAINTENANCE, USE, OR INABILITY TO USE THE PRODUCT, EVEN IF DIMPLEX OR ITS DIRECTORS, OFFICERS, OR AGENTS HAVE BEEN ADVISED OF THE POSSIBILITY OF SUCH LOSSES, COSTS OR DAMAGES, OR IF SUCH LOSSES, COSTS, OR DAMAGES ARE FORESEEABLE. IN NO EVENT WILL DIMPLEX, OR ITS OFFICERS, DIRECTORS, OR AGENTS BE LIABLE FOR ANY DIRECT LOSSES, COSTS, OR DAMAGES THAT EXCEED THE PURCHASE PRICE OF THE PRODUCT.

SOME JURISDICTIONS DO NOT ALLOW THE EXCLUSION OR LIMITATION OF INCIDENTAL OR CONSEQUENTIAL DAMAGES, SO THE ABOVE LIMITATION OR EXCLUSION MAY NOT APPLY TO THE PURCHASER.

How State and Provincial law apply

This limited warranty gives you specific legal rights, and you may also have other rights which vary from jurisdiction to jurisdiction. The provisions of the United Nations Convention on Contracts for the Sale of Goods shall not apply to this limited warranty or the sale of products covered by this limited warranty.